

# AXIOM

# INDUSTRIES LTD.

## **MODEL SF100-HP-L PACKAGED HYDRONIC SYSTEM FEEDER HIGH PRESSURE LARGE CAPACITY TANK**

*The SF100-HP-L contains everything required to feed and pressurize closed hydronic heating or cooling systems in a neat, simple package that is easy to install and operate. It is compatible with both water and water/glycol solutions.*

**25-85 psi**



### **FEATURES and BENEFITS**

- 383 litre(100 US gallon) tank for storage and mixing
- Plugs into any standard 115 VAC outlet
- Fluid level switch shuts the pump off if the storage tank level gets low
- Accumulator tank prevents excessive pump cycling
- No direct connection to potable water supply eliminates need for backflow prevention
- Make-up fluid stored in the feeder tank can be pre-treated
- Diverter valve for purging of air on initial start-up and manual agitation of solution
- Prevents major floods - in the event of system rupture, only the contents of the tank can be pumped into the system
- Provides leak detection - dropping fluid level provides immediate notice that the system has developed a leak
- Fluid drained for service can easily be put back into the system
- Flexible connection hose with system check valve makes installation easy

Represented By:

AXIOM INDUSTRIES LIMITED 2615 WENTZ AVENUE SASKATOON, SK S7K 5J1  
TOLL FREE : (877) 651-1815 PHONE : (306) 651-1815 FAX : (306) 242-3373

[www.axiomind.com](http://www.axiomind.com)



**INDUSTRIES LIMITED**

**SF100-HP-L HYDRONIC SYSTEM FEEDER TECHNICAL INFORMATION**

**WEIGHT** – 22.7 Kg, 50 lbs.

**ELECTRICAL**

115/60/1, 0.9 amps  
3-prong plug and cord

**PUMP PERFORMANCE**

0.10 l/s (1.6 gpm) @ free flow  
0.08 l/s (1.3 gpm) @ 585 KPa (85 psi)  
Self-priming up to 2.1 m (7 feet)  
Maximum liquid temp. 77 C (170 F)

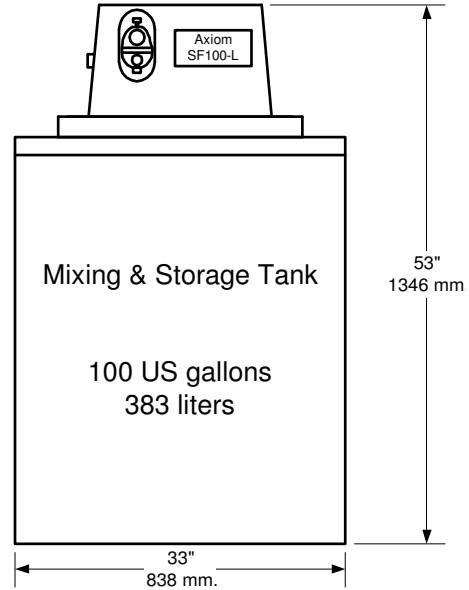

Certified to CAN/CSA  
C22.2 No. 68



9901055  
Conforms to UL73

**Intertek**

**SPECIFICATION**

Hydronic system feeder shall be AXIOM INDUSTRIES LTD. Model SF100-HP-L. System shall include 383 litre (100 US gallon) storage/mixing tank with cover; pump suction hose with inlet strainer; pressure pump with thermal cut-out; integral pressure switch; integral check valve; cord and plug; pre-charged accumulator tank with EPDM diaphragm; manual diverter valve for purging air and agitating contents of storage tank; pressure regulating valve adjustable (173 – 600 KPa; 25 – 85 psig) complete with pressure gauge; built-in check valve; union connection; 12 mm (½”) x 900 mm (36”) long flexible connection hose with check valve; low level pump cut-out. Pressure pump shall be capable of running dry without damage. Power supply 115/60/1 0.9 A. Unit shall be completely pre-assembled and certified by a recognized testing agency to CSA standard C22.2 No 68.

**ACCESSORIES**

- 2PRV** – Second Pressure Reducing Valve, Pressure Gauge, System Connector Hose and Check Valve to allow for independent pressure supply to a second system.
- RIA10-1-SAA** – Low Level Alarm Panel c/w Remote Monitoring Dry Contacts and Selectable Audible Alarm

**LIMITED WARRANTY**

The SF100-HP-L is warranted against defects in materials and workmanship for one year.

Project \_\_\_\_\_ Location \_\_\_\_\_  
 Consultant \_\_\_\_\_ Contractor \_\_\_\_\_  
 Unit Tag \_\_\_\_\_ Sales Agent \_\_\_\_\_