



DMF300 'PRESSURE PAL' DIGITAL MINI SYSTEM FEEDER

*The industry leader for pressurizing closed-loop hydronic systems introduces the newest 'PRESSURE PAL' to the Axiom Product Family. The **DMF300** utilizes a digital pressure control (0-45 psig) with electronic alert contacts. Front fill point makes fluid handling a simple process.*

FEATURES and BENEFITS

- 64 litre (17 US gallon) tank for storage and mixing
- All features shown on **user friendly digital display screen**
- **0-45psig** Pressure Setpoint with adjustable dead band
- N.O./N.C. Alert contacts and LED light enabled when low level, low pressure, or high-pressure condition
- **Tilted 5" easy fill access on front of tank**
- UL listed Power supply plugs into any standard 115 VAC outlet
- Diaphragm pump can run dry without damage
- No direct connection to potable water supply eliminates need for backflow prevention
- Make-up fluid stored in the feeder tank can be pre-treated to meet appliance manufacturers specifications
- Fluid level switch shuts the pump off and enables alarm contacts if the storage tank level gets too low
- Diverter valve allows easy purging of air on initial start-up, and manual mixing of solution
- Fluid drained for service can easily be put back into the system
- Prevents major floods
- Provides leak detection



Modern Design, Simple Control, Reliable Quality

TOLL FREE: (877) 651-1815 PHONE: (306) 651-1815 EMAIL: info@axiomind.com

www.axiomind.com



INDUSTRIES LIMITED

DMF300 HYDRONIC SYSTEM FEEDER TECHNICAL INFORMATION

WEIGHT

6.8 kg, 15 lbs.

ELECTRICAL

Fused Power supply adapter (UL listed) 115/60/1 to 24 VDC
Rated 50 watts AC
LED Power Light

PUMP PERFORMANCE

3.78 l/m (1.0 gpm) @ free flow
Self-priming up to 1.2 m (4 feet)

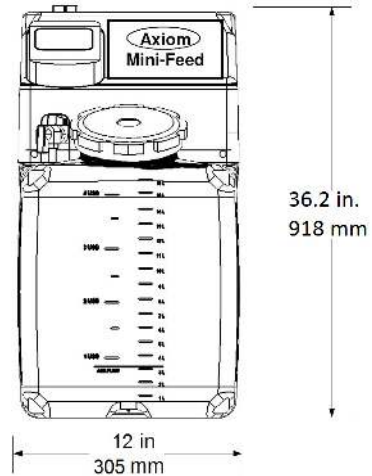

Depth – 12.0 in (305 mm)
Clearances – Right/Left - 0 in (0mm)
provided side screws on lid are removed upon installation
Clearances – Top – 3” (75mm)
Discharge 1/2” FNPT

SPECIFICATION

Hydronic system feeder shall be AXIOM INDUSTRIES LTD. Model DMF300. System shall include 64 litre (17 U.S. gallon) storage/mixing tank with molded-in level gauge, 125 mm (5”) fill/access opening and cover; pump suction hose with inlet strainer; pressure pump with fuse protection; check valve; low fluid level pump cut-out float switch; manual diverter valve for purging air and agitating contents of storage tank; digital pressure switch adjustable from 0 kPa (0 psig) to 310 kPa (45 psig) cut-out pressure; factory cut-out pressure set to 115 kPa (18psig); digital pressure display, visual alarm on low level, low level alarm comes with remote dry contacts. Unit to be c/w UL listed and fused power supply adapter with LED power indicator light, 100-240VAC/50-60Hz/1 to 24 VDC, supplied loose for field installation.

Alarm dry contact (blue and green wire) rating: 5A/125VAC 28VDC.

Feeder shall be compatible with glycol solutions of up to 50% concentration. Pump shall be capable of running dry without damage. Unit shall be completely assembled.

ACCESSORIES

RIA10-1-SAA – Low level Alarm Panel c/w Remote Monitoring Dry Contacts and Selectable Audible Alarm

LIMITED WARRANTY

The DMF300 is warranted against defects in materials and workmanship for one year.

Project _____ Location _____
Consultant _____ Contractor _____
Unit Tag _____ Sales Agent _____