



## ***MODEL NT25-P18 CONDENSATE NEUTRALIZATION TANK WITH PUMP***

The NT25-P18 is ideal for installations that require both condensate removal and neutralization.

The condensate produced by gas fired condensing appliances is acidic and has the potential to harm the environment and the sewer system.

# NeutraPump™



### **FEATURES and BENEFITS**

- **40 Gal/hr (150 l/hr)\***
- **18 feet of lift at max design flow rate**
- **Comes with high level float for hook up to alarm system**
- **NeutraPump prevents acidic condensate from corroding drains and sewer systems**
- **Neutralized condensate is more environmentally friendly**
- **Low profile design for appliances with near floor condensate drain**
- **All materials made from corrosion resistant material**
- **18 liter (4.8 US gallon) tank with serpentine flow path through LipHter media for complete neutralization**
- **Includes initial charge of Axiom's special LipHter neutralizing media**

\* Check with the appliance manufacturer for condensate flowrate or go to our website and use the sizing calculator. As a guideline 6,000,000 BTU/hr at 96% efficiency will produce approximately 40 Gal/hr (150 L/hr).

TOLL FREE: (877) 651-1815 PHONE: (306) 651-1815 EMAIL: info@axiomind.com

[www.axiomind.com](http://www.axiomind.com)



**NT25-P18 CONDENSATE NEUTRALIZATION TANK WITH PUMP  
TECHNICAL INFORMATION**

**WEIGHT**

23 kg, 51lbs. (full)

**ELECTRICAL**

Pump: 120VAC 60Hz, 87W, 0.89 Amps  
High level safety switch rating: 125 or 250VAC 6A,  
125V DC 0.4A, 250V DC 0.3A

**PUMP PERFORMANCE**

Submerged pump is self-priming  
282 l/hr (74 gph) @ free flow  
150 l/hr (40 gph) @ 5.5 m (18 ft)

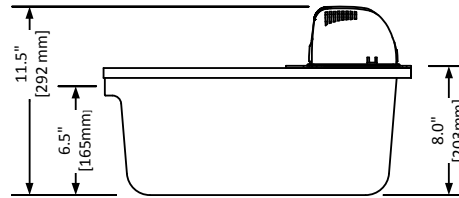
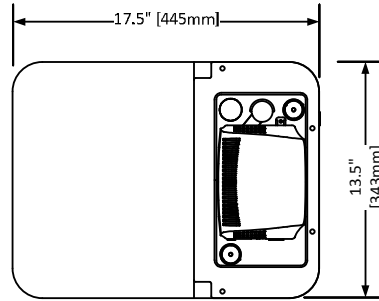
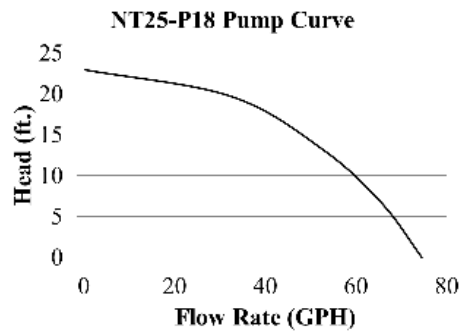

**Clearance - Top  
4\"/>**

Pump is certified to  
CAN/CSA STD  
C22.2 no. 108



4007096  
Pump conforms to  
ANSI/UL STD 778

**SPECIFICATION**

The condensate neutralization tank with pump shall be AXIOM INDUSTRIES LTD. Model NT25-P18. System shall include 18 litre (4.8 U.S. gallon) tank and lid made from polypropylene construction; S.S. mounting bracket and screws; pump with thermal cut-out and electrically certified to CAN/CSA std C22.2 no. 108-1 and conforms to ANSI/UL std 778, low level float switch; high level float switch with N.C. or N.O. contacts (factory set to N.C.) for remote alarm system; check valve; 20 feet of 3/8\"/>

**ACCESSORIES**

- NM-25** – replacement LipHter neutralization media
- RIA10-1-SAA** – High level alarm panel provides audible and visual alarm for high level indication



**LIMITED WARRANTY**

The NT25-P18 is warranted against defects in materials and workmanship for one year.

Project \_\_\_\_\_ Location \_\_\_\_\_  
 Consultant \_\_\_\_\_ Contractor \_\_\_\_\_  
 Unit Tag \_\_\_\_\_ Sales Agent \_\_\_\_\_