



FH SERIES FILTER HOUSING

Axiom's Hydronic Filter Housing delivers effective ongoing protection against the damaging effects of debris in all types of heating and cooling systems. Maintaining a clean hydronic system fluid has never been easier.

Max. Temperature: 250°F (121°C)

Max. Pressure: 300psi (2068kPa)

Connections: FNPT (¾" or 1")

Compatible fluids: Water, Propylene glycol, Ethylene glycol, Methanol (50%), Ethanol (50%)



FEATURES and BENEFITS

- *Double O-ring on filter housing for reliable leak free cartridge replacements*
- *Ball valve drain with hose connection and cap ensures safe fluid handling*
- *Filter vessel can be used for chemical dosing. Up to 0.8 Gallon (3.0 litre)*
- *Stainless Steel construction*
- *Reduces equipment maintenance cost and extends system life*



INDUSTRIES LIMITED

	Model	Size	Flow Rate	Filter Size	Vessel Volume
<input type="checkbox"/>	FH-10	¾"	1-10 gpm (0-38 l/min)	10" (254mm) DOE cotton wound	0.4 gal (1.5L)
<input type="checkbox"/>	FH-20	1"	10-20 gpm (38-76 l/min)	20" (508mm) DOE cotton wound	0.8 gal (3.0L)

SPECIFICATION

Hydronic Filter Housing shall be AXIOM INDUSTRIES LTD. model FH-_____. System shall include of 304SS filter housing and head, two EPDM O-rings, brass drain valve with barb fitting and cap, opening tool, and wall mounting bracket.

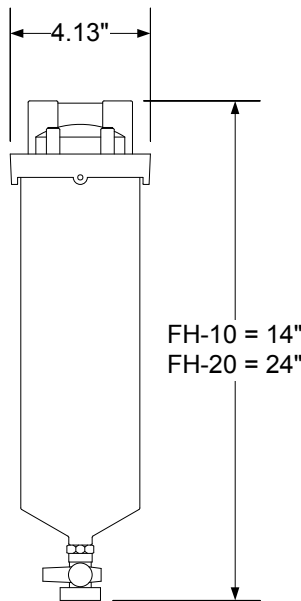

PARTS

- SFP-10-5M** – 5 micron cartridge replacement for 10" filter housing
- SFP-10-25M** – 25 micron cartridge replacement for 10" filter housing
- SFP-20-5M** – 5 micron cartridge replacement for 20" filter housing
- SFP-20-25M** – 25 micron cartridge replacement for 20" filter housing

LIMITED WARRANTY

The Axiom FH filter housing is warranted against defects in materials and workmanship for one year.

Project _____ Location _____
 Consultant _____ Contractor _____
 Unit Tag _____ Sales Agent _____