



INDUSTRIES LIMITED

Installation, operation, and maintenance instructions for the Puropal-Pro-25 and Puropal-Pro-50 H₂O demineralizers

Function

The Puropal-Pro filters lime and aggressive dissolved substances such as sulfates, nitrates and chlorides out of the local domestic water. The device operates on the basis of a mixed bed ion exchange resin and provides completely demineralized water that meets fill water specifications of glycol and boiler manufacturers. It is also possible to demineralize an existing “water only” system by circulating the system water through the Puropal-Pro demineralizing cart. This method does not release any chemical additives into the water. The device operates without an external power supply. Not for drinking water.

The filling apparatus is equipped with precise meters for monitoring pure water production in terms of quality and quantity.

If the mixed bed ion exchange resin capacity is exhausted, then it can be easily replaced and disposed of with the household waste.



Protective measures

Only trained personnel should use the filling apparatus.

Operating specifications must be adhered to according to this manual.

Local guidelines are to be followed for the connection between the local domestic water supply and the closed loop hydronic system.

The system is not suitable for unmonitored, permanent connection under pressure. The valves in the input and output are to be kept closed and only to be opened for the duration of the system filling.

Even demineralized water contains dissolved gasses, including oxygen and carbon dioxide that can cause the beginning of the corrosion process. The gases are purged by heating the water, therefore we recommend carrying out a heating test run for the system as soon as possible after fill-up.

Connection

The input for the untreated water is on the left, the output for the demineralized water for the closed loop hydronic system is on the right. See Fig. 1 below.

The equipment contains a non-return valve. When the connections are closed, the untreated water cannot flow through the apparatus.

Puopal-Pro may only be under pressure for the duration of the filling process. A permanent connection under pressure is not permitted. Under normal domestic water pressure the flow rate through the Puopal Jr. Pro is approximately 6.6 gpm (25 l/min).

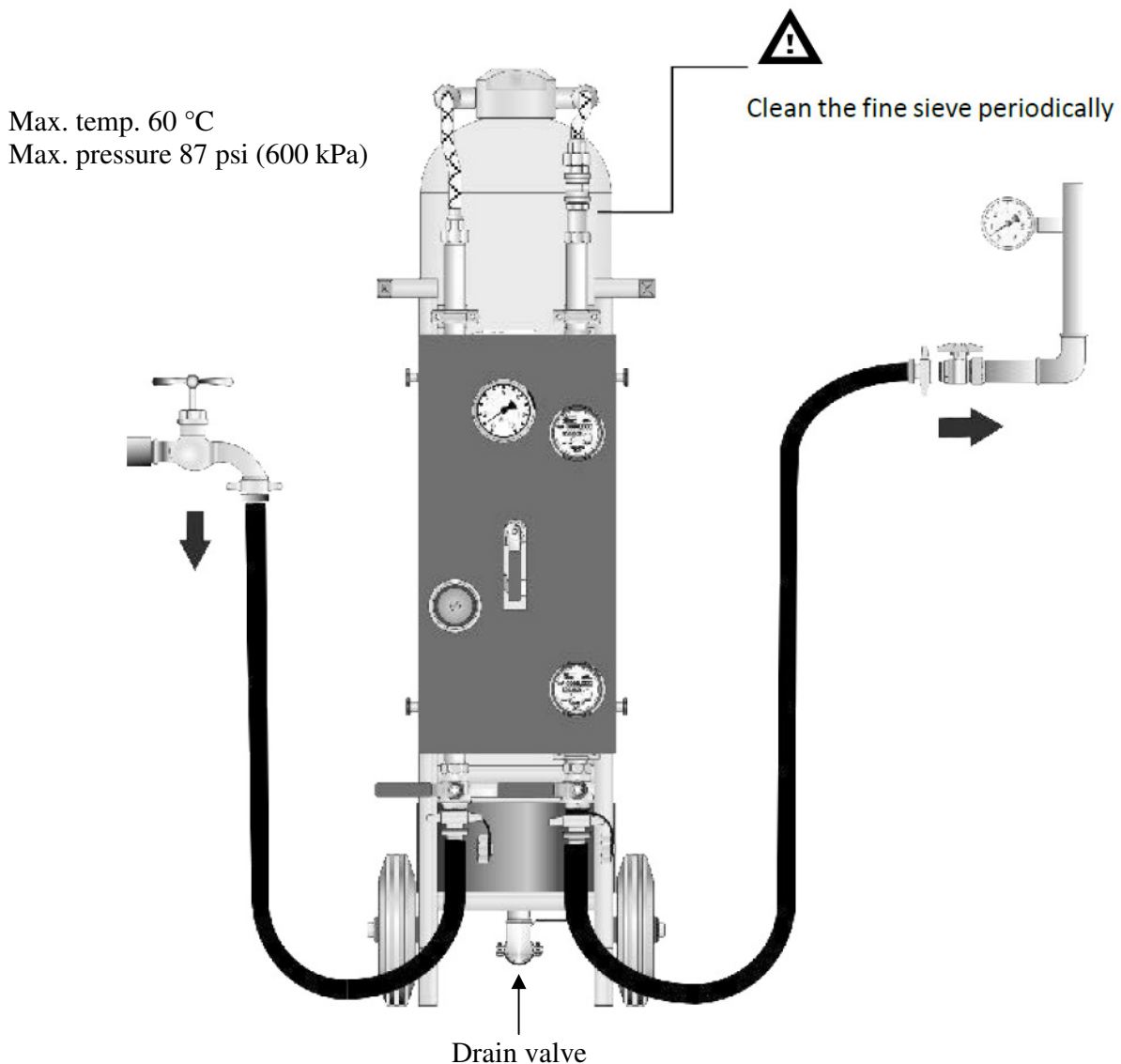

Figure 1: Connections



Open the drain valve on the cartridge only when replacing the resin and only if a hose is connected to the collection sack. Under no circumstances should you connect the drain valve to a water supply system.

Empty the water content of the cartridge once before each use since bacteria can build up between uses. Check to ensure there are no resin pellets in the water.

Operation

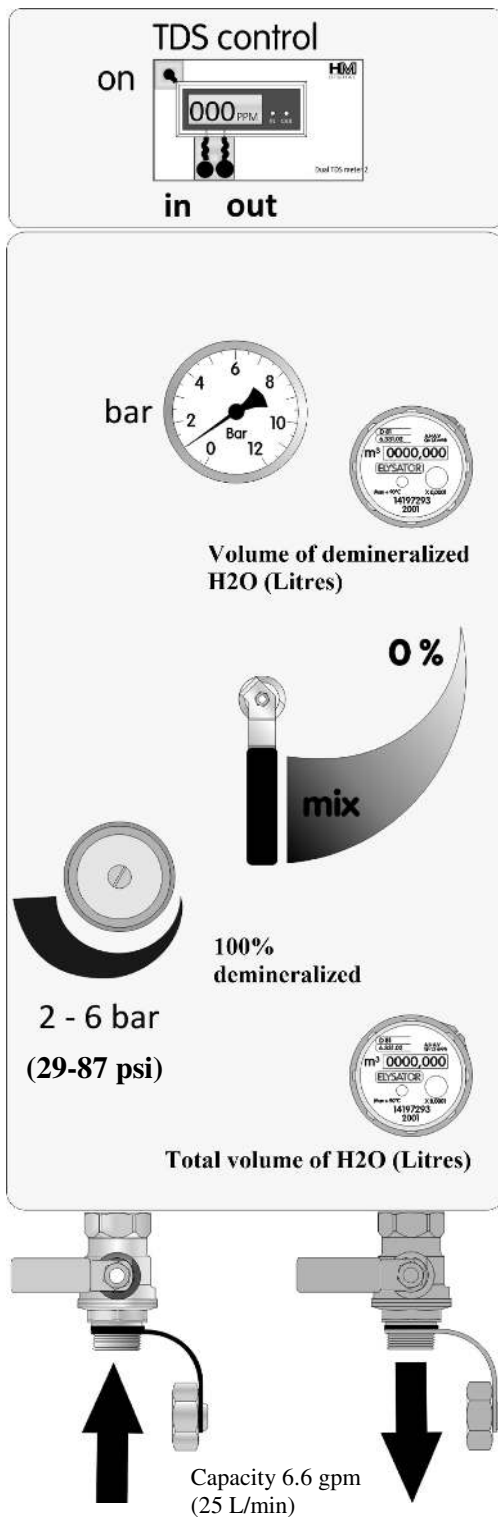

Fig. 2: Operation

TDS measuring device

The battery powered meter shows the TDS (total dissolved solids) in ppm in the water. See Fig. 2.

Operation: Switch on using the red button on the top left, then select the measuring point, (inlet or outlet). As soon as the value on the output is > 20 ppm the resin in the cartridge is exhausted. The untreated water hardness can be determined by measuring the value at the inlet and the capacity of the resin can be calculated off the capacity graphs (Fig. 3).

In order to conserve batteries, the meter turns off automatically after 20 seconds. Reset if necessary.

Flow and quantity meter

The volume of demineralized, and total water can be read off the flow meters.

Operation: The places after the comma show the litres, the places in front of the comma show the cubic metre (1,000 litres). Example: 0001.248 is 1,248 L (3.8 L = 1 US gal.). The top flow meter shows the quantity of completely demineralized water, the bottom meter shows the total amount of water, including mixed water.

It is recommended to log the last meter reading when changing the resin because the meter cannot be reset.

Mixing valve

If demineralization only suffices up to a certain hardness, then untreated water can be added. The mixing valve is used as well when cleaning the closed loop hydronic system: Rinse with untreated water and then fill the closed loop hydronic system with demineralized water by moving the valve lever.

Pressure reducing valve

The pressure reducing valve regulates the pressure of the untreated water with regard to the system.

Operation: Use the screw driver to turn the adjusting screw in the center of the valve: To the left: pressure is reduced; to the right, pressure is increased. The higher the pressure, the faster the water flows through the fill-up station. The adjusted pressure can be read off the pressure gauge.



The pressure may not be adjusted higher than what the pressure the relief valve of the closed loop hydronic system is set to. In case of doubt, do not set higher than 30 psi (207 kPa).

Capacity of the ion exchanger

The capacity of the ion exchange resin depends on the water hardness. The capacity for the Puropal-Pr- 25/50 can be read off Fig. 3 below. Example: With a hardness of 11.7 gpg (200 ppm), Puropal-Pro-25 provides 725 gal (2750 L) of completely demineralized water, and Puropal-Pro-50 provides 1780 gal (6750 L).

Capacity of the Puropal-Pro-25/50

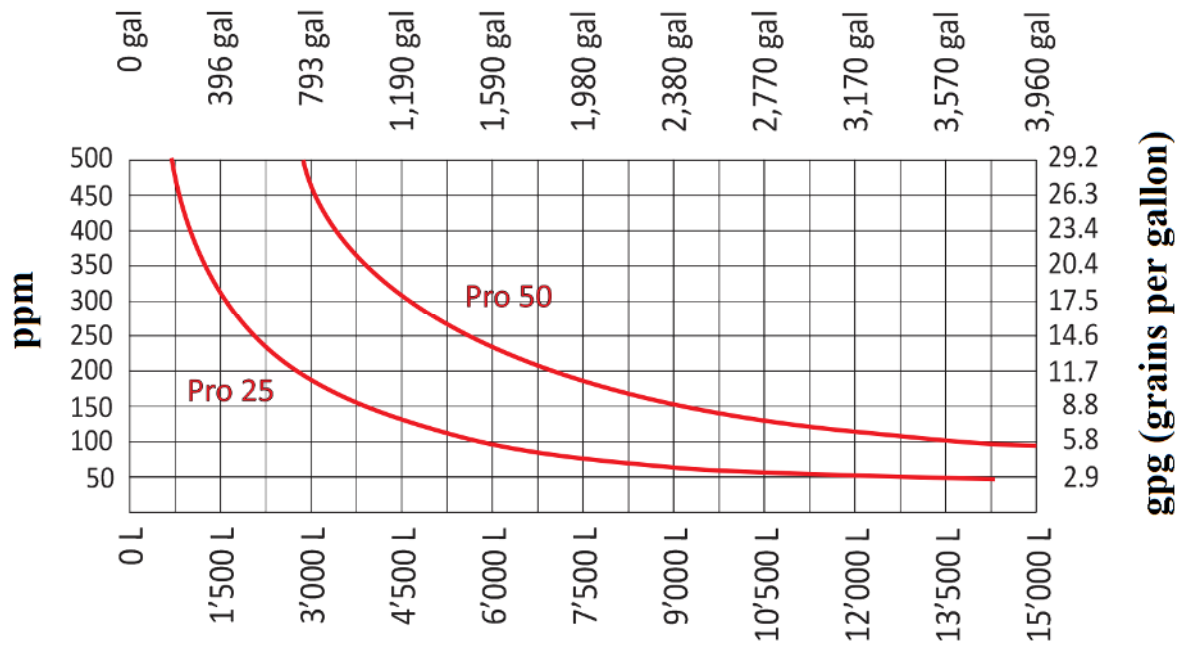

Figure 3: Volume of water that the Puropal-Pro-25/50 can completely demineralize based on TDS (total dissolved solids) measured in ppm, or gpg (grains per gallon).

Replacing ion exchange resin

If the content of dissolved solids in the treated water exceeds 30 ppm TDS (approx. 2 grains per gallon) according to the meter, then the resin must be changed. We first recommend that you briefly interrupt the water supply, shake the cartridge and then slowly turn the water supply back on and fill-up. The mixing and flow rate restriction will help use up the last of the resin.

- a) Emptying used resin. See Fig. 4 below.
 1. Close ball valve 1) and 2) at the cartridge inlet and outlet. Leave the Puropal-Pro connected to the untreated water tap 3).
 2. Connect hose to drain valve 4) and insert it into the supplied water-permeable collection sack. Tightly connect the sack to the top of the hose with a cable binder or tape.
 3. Open the drain valve 4).
 4. Open ball valve 1) at the inlet.
 5. Let the resin drain out and then close the ball valve in inlet 1) again.
 6. Let the cartridge drain and then close drain valve 4).
 7. If the collection sack is dripping with resin, then dispose of it in the household waste.



Open the drain valve on the cartridge only when replacing the resin and only if a hose is connected to the collection sack. Under no circumstances should you connect the drain valve to a water supply system.

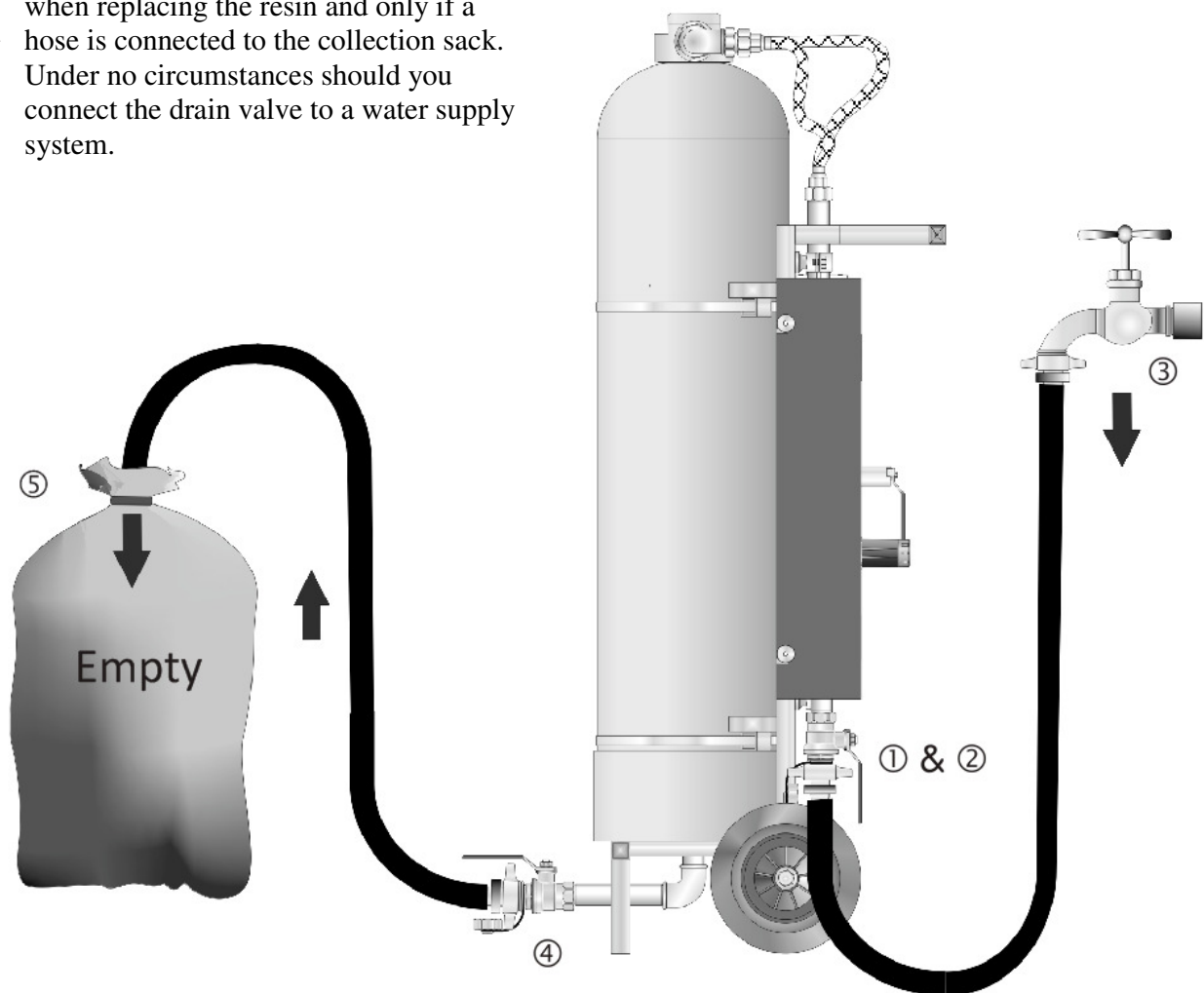

Figure 4: Emptying used resin

b) Fill with new resin. See Fig 5 below.

1. Loosen both reinforced hose screws 1) from the apparatus (not at the top on the head).
2. Hold head 2) by hand and unscrew carefully.
3. Remove head together with the spray hose 3).
4. Fill with Puopal resin 5) using funnel 4). Puopal-Pro-25 = one 6.6 gal. (25 L) sack, Puopal-Pro-50 = two 6.6 gal. (25 L) sacks.
5. Replace head with spray hose. Make sure that the spray hose is pressed into the head until it is tight and sealed; otherwise, resin will leak into the system.

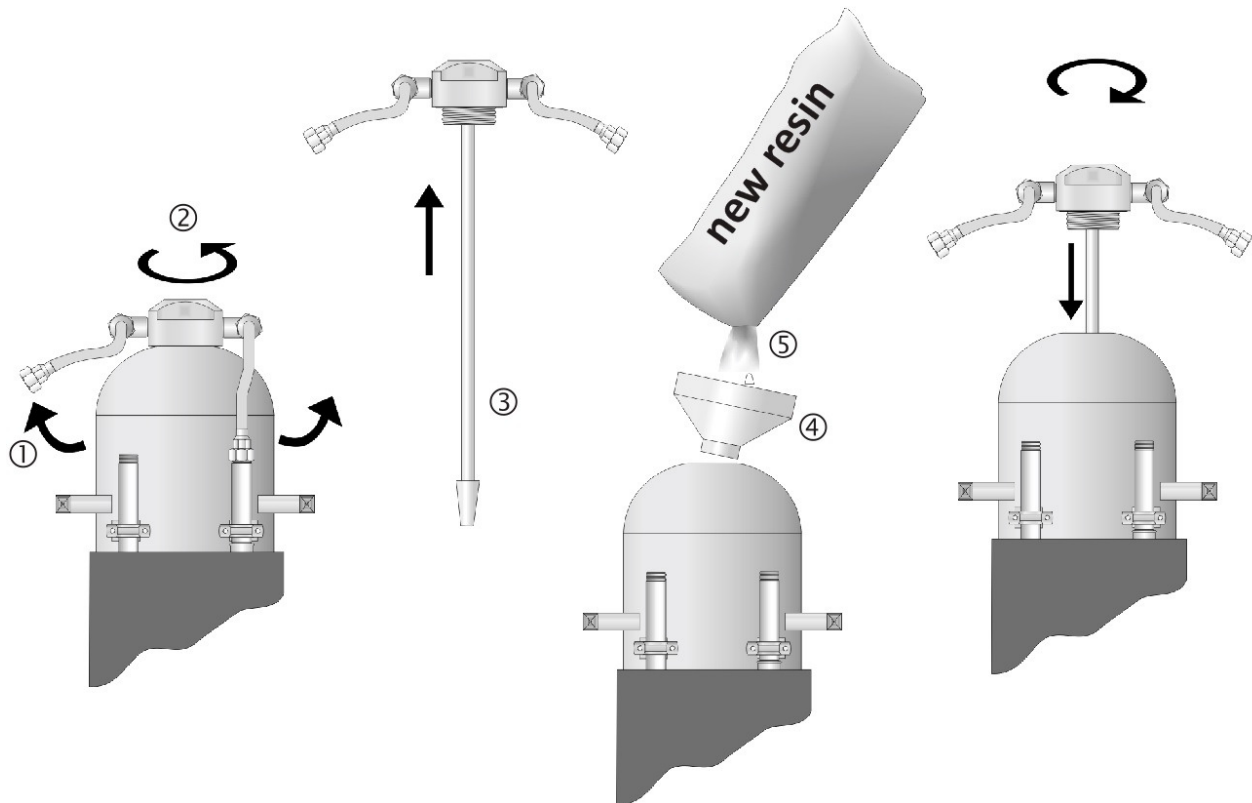

Figure 5: Filling the Puopal-Pro with new resin



Check that the spray hose is pressed tightly into the head and is sealed otherwise resin will leak into the system.

Make sure that no resin ends up on the floor. This represents a significant slipping hazard. Carefully and thoroughly remove any spilled resin off the floor (e.g. with a vacuum cleaner).

The resin pellet is to be stored in a moist place, which is why it is supplied in sealed plastic bags. Once the bags are opened, use the resin immediately. The resin can be stored in a cool dark place for up to 12 months. There is the risk of capacity loss and bacteria formation if incorrectly stored.

Trouble shooting the TDS meter

Malfunction	Solution
The display goes off after approx. 20 seconds.	This is not a malfunction; it automatically switches off to conserve the batteries. Press the "POWER" button again.
The inlet value (IN) shows -000-	The sensor in the inlet has no measuring values or is defective. Use the flush valve to check whether the whole unit is full of water. If this is the case and the malfunction persists, then the measuring device and sensor must be replaced.
The outlet value (OUT) shows -000-	Check the water meter to see whether the whole unit is full of water. If this is the case, then this is not a malfunction, instead it is a correct measurement of the demineralized water. If it can be assumed that the cartridge is exhausted (due to the amount of treated water) and the display remains on -000-, then the measuring device should be replaced along with the sensor.
The display remains empty, even after pressing the "POWER" button.	Change batteries. See Fig 6 below.
The display flutters, is difficult to read or contains illegible characters.	Change batteries. See Fig 6 below.
The display shows -ERR-	Measuring device malfunction. Reset by switching on and off quickly 2-3 times until the display is normal again. Otherwise, remove and reinsert the batteries.
The resin seems to be used faster (increased TDS) than the water	There probably is not a malfunction, instead the untreated water contains dissolved solids (sulfate, nitrate, chloride) in addition to lime, which are removed and thus reduce the capacity. Otherwise there is a flow measurement malfunction (see below)

Changing the batteries

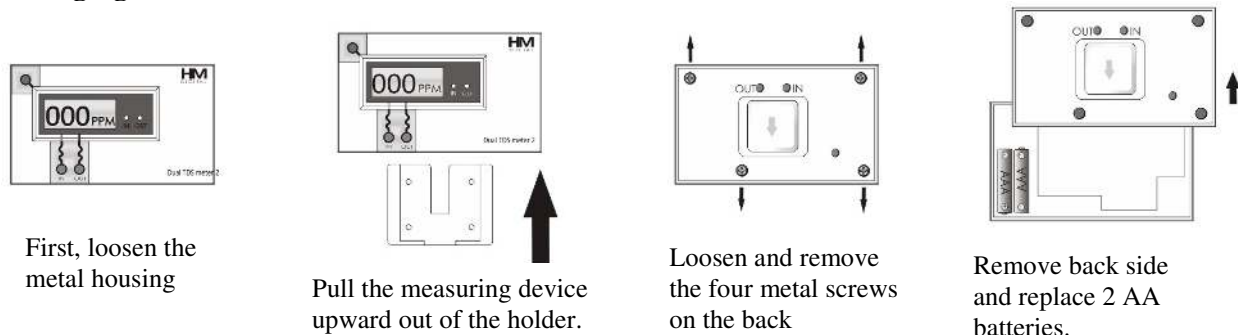

Figure 6: Changing the batteries

Flow rate measurement device malfunction

The water meters appear to be too slow or to not run at all.	A fine sieve is installed in front of the outlet valve in order to prevent resin from leaking into the system from the apparatus due to an operation failure. If resin does leak out of the cartridge, it is caught in the fine sieve and interrupts the function of the armatures. Solution: Rinse and clean armatures out.
--	--

Reduced flow rate

Malfunction	Solution
The flow drops below 15 L/min (4 gpm)	The pressure difference between the water supply line and the counter-pressure from the system is too low. Open the pressure reduction valve again.
The flow is weak despite the unrestricted supply line	The fine sieve in the outlet (right side) of the cartridge is blocked. Loosen screw, rinse out fine sieve and reattach. See Fig. 7 below.

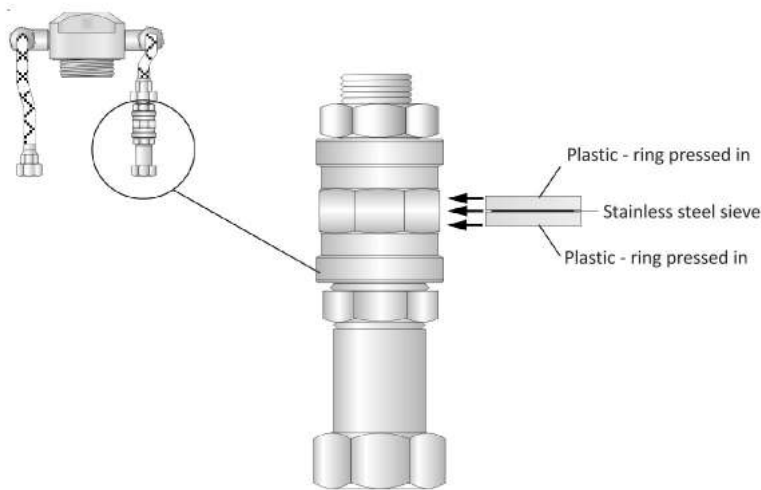

Figure 7: Location of fine sieve at outlet

Drain sieve for residual water

Damage!	Preventative solution
The residual water in the resin tank can freeze causing components to burst!	Frost damage can be prevented by blowing out residual water with the supplied drain sieve. See Fig. 8 below.
	In order to change the resin, the drain sieve must be removed.

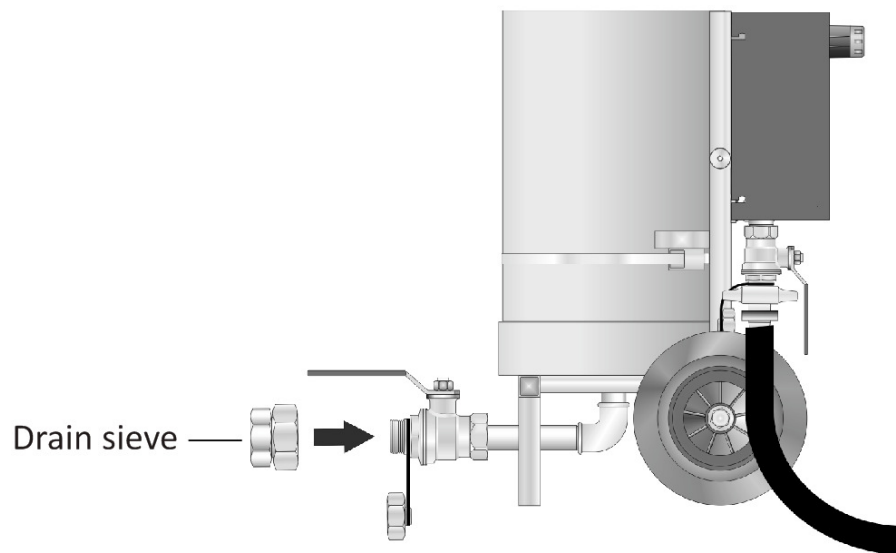

Figure 8: Apply drain sieve before blowing out residual water in the tank.