



## **DMF150 'PRESSURE PAL' DIGITAL MINI SYSTEM FEEDER**

*The industry leader for pressurizing closed-loop hydronic systems introduces the newest 'PRESSURE PAL' to the Axiom Product Family. The **DMF150** utilizes a digital pressure control (0-45 psig) with electronic alert contacts. The tank design incorporates a wall bracket connection that comes standard in the box. Front fill point makes fluid handling a simple process.*



### **FEATURES and BENEFITS**

- 17 litre (4.6 US gallon) tank for storage and mixing
- All features shown on **user friendly digital display screen**
- **0-45psig** Pressure Setpoint with adjustable dead band
- N.O./N.C. Alert contacts and LED light enabled when low level, low pressure, or high-pressure condition
- Integrated Easy Connect Wall Mount Bracket comes with the unit
- **Tilted 5" easy fill access on front of tank**
- UL listed Power supply plugs into any standard 115 VAC outlet
- Diaphragm pump can run dry without damage
- No direct connection to potable water supply eliminates need for backflow prevention
- Make-up fluid stored in the feeder tank can be pre-treated to meet appliance manufacturers specifications
- Fluid level switch shuts the pump off and enables alarm contacts if the storage tank level gets too low
- Diverter valve allows easy purging of air on initial start-up, and manual mixing of solution
- Fluid drained for service can easily be put back into the system
- Prevents major floods
- Provides leak detection

Modern Design, Simple Control, Reliable Quality

TOLL FREE: (877) 651-1815 PHONE: (306) 651-1815 EMAIL: [info@axiomind.com](mailto:info@axiomind.com)

[www.axiomind.com](http://www.axiomind.com)



**INDUSTRIES LIMITED**

**DMF150 HYDRONIC SYSTEM FEEDER TECHNICAL INFORMATION**

**WEIGHT** – 4.5 kg, 10 lbs.

**ELECTRICAL**

Fused Power supply adapter (UL listed) 115/60/1 to 24 VDC  
Rated 50 watts AC  
LED Power Light

**PUMP PERFORMANCE**

3.78 l/m (1.0 gpm) @ free flow  
Self-priming up to 1.2 m (4 feet)

**SPECIFICATION**

Hydronic system feeder shall be AXIOM INDUSTRIES LTD. Model DMF150. System shall include 17 litre (4.5 U.S. gallon) storage/mixing tank with molded-in level gauge, 125 mm (5”) fill/access opening and cover; pump suction hose with inlet strainer; pressure pump with fuse protection; check valve; low fluid level pump cut-out float switch; manual diverter valve for purging air and agitating contents of storage tank; digital pressure switch adjustable from 0 kPa (0 psig) to 310 kPa (45 psig) cut-out pressure; factory cut-out pressure set to 115 kPa (18psig); digital pressure display, visual alarm on low level, low level alarm comes with remote dry contacts; wall mounting bracket. Unit to be c/w UL listed and fused power supply adapter with LED power indicator light, 100-240VAC/50-60Hz/1 to 24 VDC, supplied loose for field installation.

Alarm dry contact (blue and green wire) rating: 5A/125VAC 28VDC.

Feeder shall be compatible with glycol solutions of up to 50% concentration. Pump shall be capable of running dry without damage. Unit shall be completely assembled.

**ACCESSORIES**

**RIA10-1-SAA** – Low level Alarm Panel c/w Remote Monitoring Dry Contacts and Selectable Audible Alarm

**LIMITED WARRANTY**

The DMF150 is warranted against defects in materials and workmanship for one year.

Project \_\_\_\_\_ Location \_\_\_\_\_

Consultant \_\_\_\_\_ Contractor \_\_\_\_\_

Unit Tag \_\_\_\_\_ Sales Agent \_\_\_\_\_

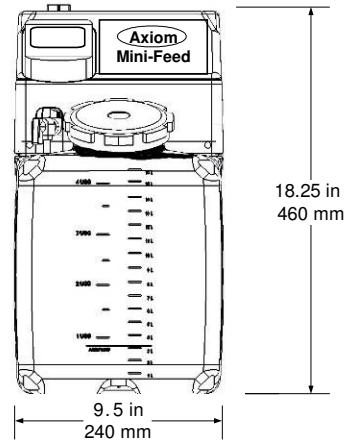

Depth - 11.00 in 280 mm  
Clearances – Right/Left/Top Side - 2 in (50mm)  
Weight When Full 50 lbs/23 kg.  
Discharge 1/2" FNPT