



**INDUSTRIES LIMITED**

**Specification:**

**AXIOM Industries Condensate Neutralization Tank with Pump: NT25-P**

The condensate neutralization tank with pump shall be AXIOM INDUSTRIES LTD. Model NT25-P. System shall include 18 litre (4.8 U.S. gallon) tank and lid made from polypropylene construction; S.S. mounting bracket and screws; pump with thermal cut-out and electrically certified to CAN/CSA std C22.2 no. 108-1 and conforms to UL std 778; low level float switch; high level float switch for remote alarm system has electrical ratings of 200VDC and 0.5A max; check valve; 1/2" FNPT outlet connection; 1" FNPT inlet; 1" NPT PVC union; 1" NPT PVC close nipple; 10 ft. long power cord. Power supply 110/60/1 1.9A. Comes with 18kg (40lbs) of Axiom's LipHter neutralization media. Total weight is 25kg (55lbs). Max fluid temperature 70°C.

**NT25-P Pump Curve**

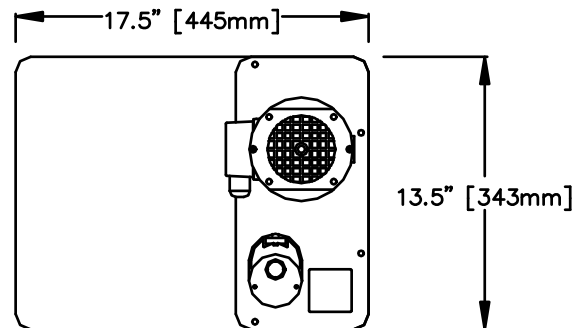
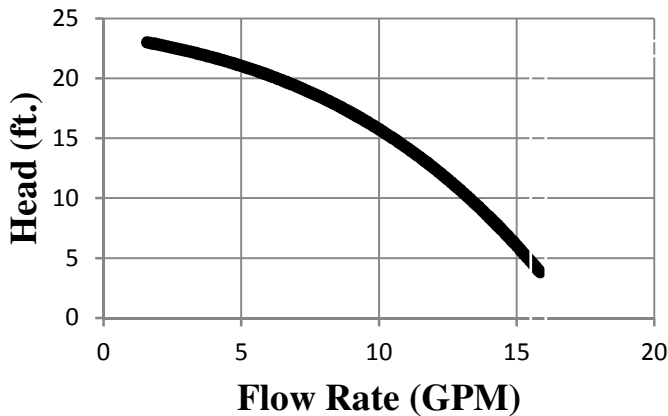

**Intertek**  
901055

Pump is certified to CAN/CSA  
std C22.2 no. 108-1  
Conforms to UL std 778

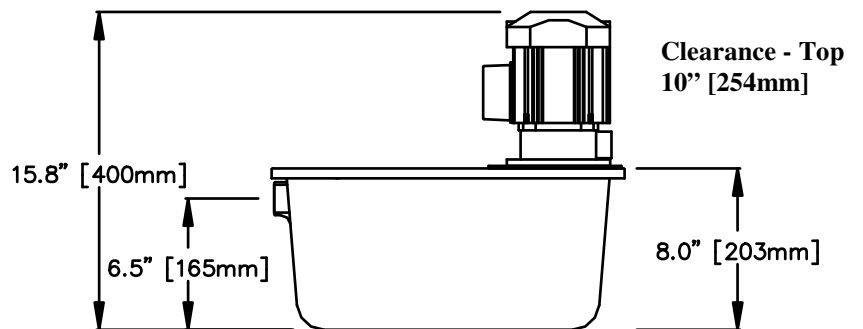

**OPTION**

**NM-25** – replacement LipHter neutralization media

**RIA10-1-SAA** – High level alarm panel provides audible and visual alarm for high level indication