

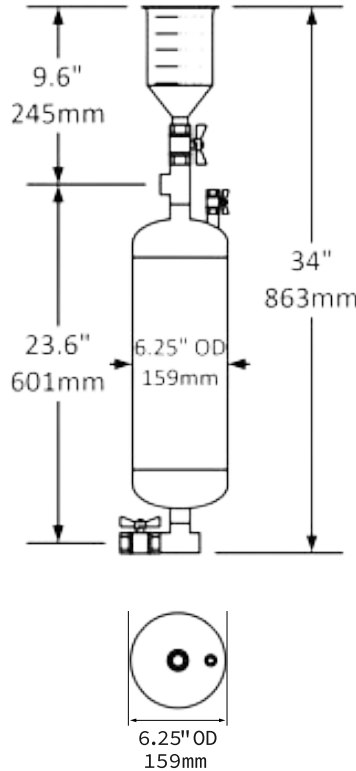

## CBF-2-SS CHEMICAL BY-PASS FEEDER TECHNICAL INFORMATION

**DIMENSIONS:**



**WEIGHT:** 11.79 kg 26 lbs

	Model	Size	Pressure Vessel Volume	Max Pressure
<input type="checkbox"/>	CBF-2-SS	¾"	2 gal (7.6L)	265psi (1.83MPa)

**SPECIFICATION:**

Chemical By-Pass Feeder shall be AXIOM INDUSTRIES LTD. model CBF-2-SS. System shall include stainless steel chemical by-pass feeder, two ¾" NPT stainless steel tees, four ¾" NPT stainless steel nipples, two ¾" NPT stainless steel ball valves, 1/4" NPT stainless steel ball valve, and 20 US oz.(600 mL) polyethylene graduated funnel with integral 20 mesh strainer, and ¾" NPT connection. The CBF series pot feeder is not for use with potable water.

**LIMITED WARRANTY:**

The Axiom CBF-2-SS Chemical By-Pass Feeder is warranted against defects in materials and workmanship for one year.

Project \_\_\_\_\_  
 Consultant \_\_\_\_\_  
 Unit Tag \_\_\_\_\_

Location \_\_\_\_\_  
 Contractor \_\_\_\_\_  
 Sales Agent \_\_\_\_\_