



***INDUSTRIES LIMITED***

Installation, Operation & Maintenance  
Instructions for SF Series Solution Feeders

Axiom Industries Ltd.  
3603 Burron Avenue  
Saskatoon, SK S7P 0E4  
Ph: (306) 651-1815  
Email: [sales@axiomind.com](mailto:sales@axiomind.com)  
Web: [www.axiomind.com](http://www.axiomind.com)



**INDUSTRIES LIMITED**

***SF100, SF100-L and SF100-HP SF100-L-HP HYDRONIC SYSTEM FEEDER***

***INSTALLATION, OPERATION AND MAINTENANCE INSTRUCTIONS***

**Installation Instructions**

***WARNING: “Risk of electrical shock”. This pump is supplied with a grounding connector and grounding-type attachment plug. To reduce the risk of electrical shock, be certain that it is connected only to a properly grounded, grounding-type receptacle. To prevent electrical shock, disconnect power before initiating any work. In the case of pump failure, the motor housing and/or the pumped fluid may carry high voltage to components normally considered safe.***

Set the solution feeder on a secure and level base. Connect the flexible hose supplied with the unit to your system connection point - use a union and isolation valve to allow for future service. **Note that the check valve supplied with the unit must be on the system end of the flexible hose.**

**NOTE - Relief and drain valves may be piped to the SF100 tank, but any holes for entry of these pipes should be cut into the side of the tank near the top rather than through the cover. This will allow the cover and top to be easily removed if necessary.**

Fill the SF100 tank with fluid. The unit is suitable for water or glycol/water solutions of up to 50% glycol concentration.

**Operation Instructions**

Leave the field installed isolation valve closed until the SF100 has been cycled and checked for leaks.

Plug the SF100 into an approved electrical outlet. The pump will start, charge the pressure tank, and stop automatically. Check to ensure that all joints are tight and there are no leaks.

**NOTE - It may be necessary to purge air from the lines before the pump can draw fluid from the tank. This can be done with the diverting valve, which is accessible through the hole on the left-hand side of the cover. Turn the valve handle so that it is vertical to purge air - return it to horizontal for normal operation.**

Verify that the outlet pressure registered on the pressure gauge meets your system needs. It is factory set at 12 psig (83 KPa), but can be increased by turning in the adjusting stem on the top of the regulating valve. **The regular SF100 or SF100L can but increased to 55 psi and the SF100-HP or SF100-HP-L can be increased to 85 psi.**

Fill your system, and then slowly open the valve isolating the system from the SF100.

**NOTE: Do not use the SF100 to fill large systems. The pump does not have a high flow rate; using it to fill large systems will cause unnecessary wear on the pump and may void the warranty.**



## **INDUSTRIES LIMITED**

Once the system is filled to the correct pressure, ensure that there is an adequate level of fluid (we recommend about 2/3 full) in the storage tank and record the fluid level. The SF100 will now feed solution automatically to maintain the desired system pressure. **The SF100 or SF100-HP has a 55 gallon (208 litre) tank and the SF100L or SF100-HP-L has a 100 gallon (383 litre) tank.**

The diverting valve, which is accessible through the hole on the left hand side of the cover, can be used to agitate or mix the solution in the tank. Turn the valve handle so that it is vertical - the pump will start automatically and re-circulate the solution back into the tank. When the solution is adequately mixed, turn the valve handle back to horizontal. The pump will re-charge the pressure tank and shut off automatically.

### **Maintenance Instructions**

Periodically check the fluid level in the storage tank, and visually examine the SF100 to ensure that it is clean and that all joints are tight. There is a strainer on the bottom of the suction hose inside the tank that should be checked monthly.

### **Solution Feeder Limited Warranty**

AXIOM Solution Feeder are warranted to be free of defects in material and workmanship under normal use, for a period of one (1) year from the date of manufacture, or one (1) year of use, with proof of purchase. This limited warranty will not exceed two (2) years, in any event.

The limited warranty will not apply to pumps that were improperly installed, misapplied, or incompatible with fluids or components not manufactured by AXIOM. Pump failure due to foreign debris is not covered under the terms of this limited warranty. AXIOM will not warrant any pump, which is damaged or modified outside the AXIOM factory.

Returns are to be shipped postage prepaid to AXIOM Industries. AXIOM shall not be liable for freight damage incurred during shipping, package returns carefully.

AXIOM's obligation under this warranty policy is limited to the repair or replacement of the pump/product. All returns will be tested per AXIOM factory criteria. Products found not defective (under the terms of this limited warranty) are subject to charges paid by the returnee for the testing and packaging of "tested good" non-warranty returns.

No credit or labor allowances will be given for pumps or products returned as defective. Warranty replacements will be shipped on a freight allowed basis. AXIOM reserves the right to choose the method of transportation.

This limited warranty is in lieu of all other warranties, expressed or implied, and no other person is authorized to give any other warranty or assume obligation or liability on AXIOM's behalf. AXIOM shall not be liable for any labor, damage or other expense, nor shall AXIOM be liable for any indirect, incidental or consequential damages of any kind incurred by the reason of the use of sale of any defective product or part. This limited warranty covers products distributed within Canada and the USA. Other world market areas should consult with the distributor for any deviation from this document



**INDUSTRIES LIMITED**

## SF100 PRESSURE REDUCING VALVE (PRV)

Pressure reducing valve for automatic control of closed loop boiler make up fluid.

|  |                  |                                 |          |
|--|------------------|---------------------------------|----------|
| <b>Specifications:</b> Product Number: | FM451            | Max. Temp continuous operation: | 180°F    |
| Size:                                  | ½" NPT Union     | Min. Temp:                      | 12°F     |
| Body:                                  | brass            | Max. pressure:                  | 150 PSI  |
| Inlet Connection:                      | ½" NPT           | Adjustment range:               | 4-60 PSI |
| Dimension (L x H):                     | 4 1/8" x 5 5/16" | Factory set at:                 | 12 PSI   |
| Weight (Lbs.):                         | 1.8              | Min. water temp:                | 40°F     |

### Operation:

The SF100 PRV valve is factory set for 12 PSI. To change setting, loosen the jam nut then turn hex head adjusting screw clockwise to increase the set pressure or counterclockwise to lower the set pressure. When desired pressure is obtained, tighten jam nut while holding adjusting screw stationary. **CAUTION:** The fast fill lever must never be left in the horizontal position. The lever must be placed in the vertical position to avoid over-pressurization and unnecessary relief valve discharge.

### Features:

- Good for 12 story building
- Adjustable 4-60 PSI
- Fast-fill
- Built-in check valve
- Stainless steel filter
- Pressure balanced piston design
- Threaded union connections
- Complete bronze

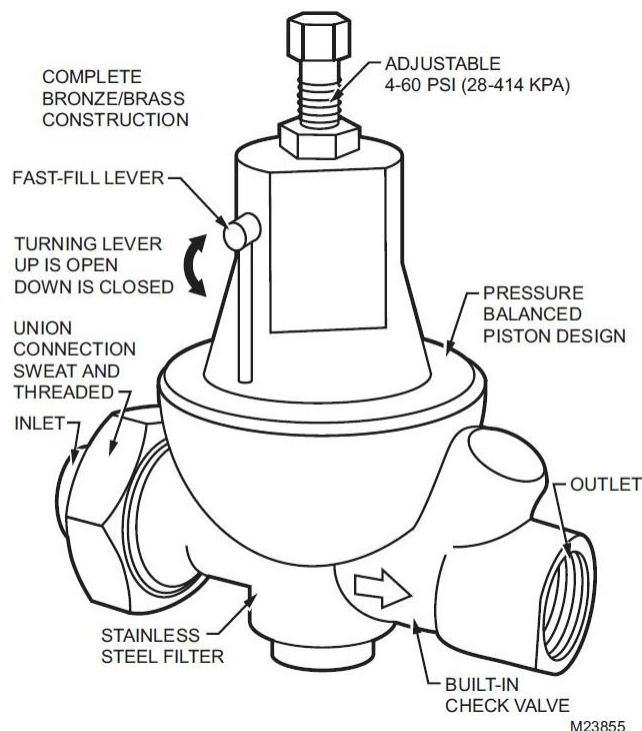

MTC-04-0302

M23855



**INDUSTRIES LIMITED**

## SF100-HP PRESSURE REDUCING VALVE (PRV)

Pressure reducing valve for automatic control of closed loop boiler make up fluid.

**Specifications:** Product Number: NR3HRSC  
Size: ½" NPT Union  
Body: brass  
Inlet Connection: ½" FNPT  
Dimension (L x H): 5 1/4" x 5 7/8"  
Weight (Lbs.): 2.0

### Operation:

The SF100-HP PRV valve is factory set for 50 PSI. To change setting, loosen the jam nut then turn hex head adjusting screw clockwise to increase the set pressure or counterclockwise to lower the set pressure. When desired pressure is obtained, tighten jam nut while holding adjusting screw stationary.

### Features:

- Max. working water pressure 400psi
- Max. working water temperature 140°F
- Reduced pressure range 15 to 150 psi
- Factory preset 50psi

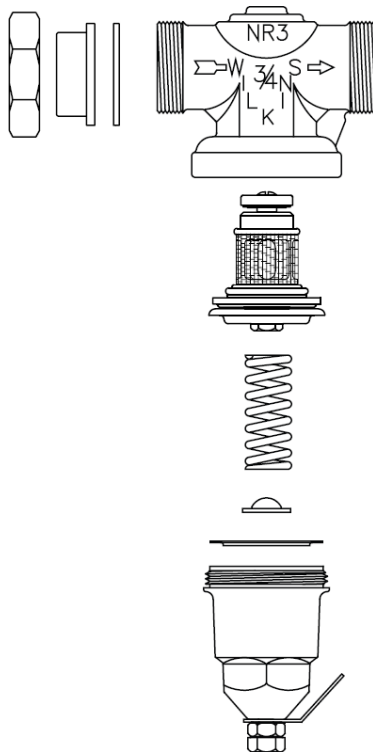



**INDUSTRIES LIMITED**

## **COLD STATIC FILL PRESSURE**

The cold static fill pressure (CSFP) in a closed hydronic system has to be high enough to accomplish three things.

- 1) Overcome the static head (height) between the fill point and the highest point in the system.
- 2) Provide adequate pressure (minimum 4 psig) at the top of the system for proper air venting.
- 3) Maintain adequate pressure at the inlet of the system pumps to prevent cavitation.

The formula for calculating the required CSFP to satisfy points 1 & 2 is:

$$(\text{Static height in feet}/2.31) + 4 = \text{CSFP in psig.}$$

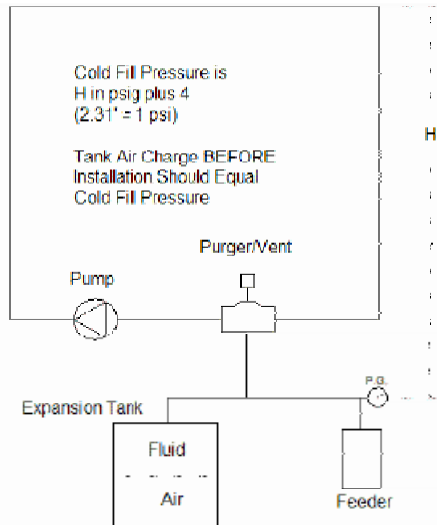

As an example, the CSFP for a system with a static height above the fill point of 40 feet would be:  $(40/2.31) + 4 = 21.3$  psig.

For most closed hydronic systems operating below about 210 F, maintaining the minimum top-of-system pressure at 4 psig will be adequate to prevent pump cavitation even if the pumps are at or near the top of the system as well.

**IMPORTANT NOTE** – For air-charged diaphragm or bladder tanks, the air charge in the tank must be adjusted to equal the cold static fill pressure before it is connected to the system.



**INDUSTRIES LIMITED**

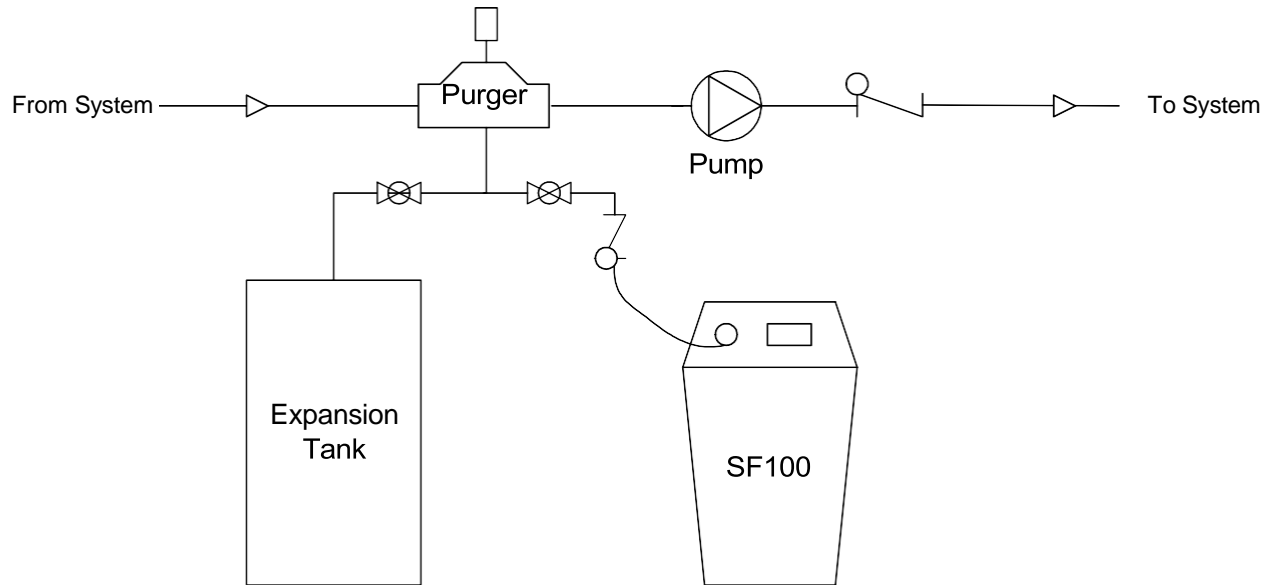

**Connection Schematic - SF100 Packaged System Feeder**



# INDUSTRIES LIMITED

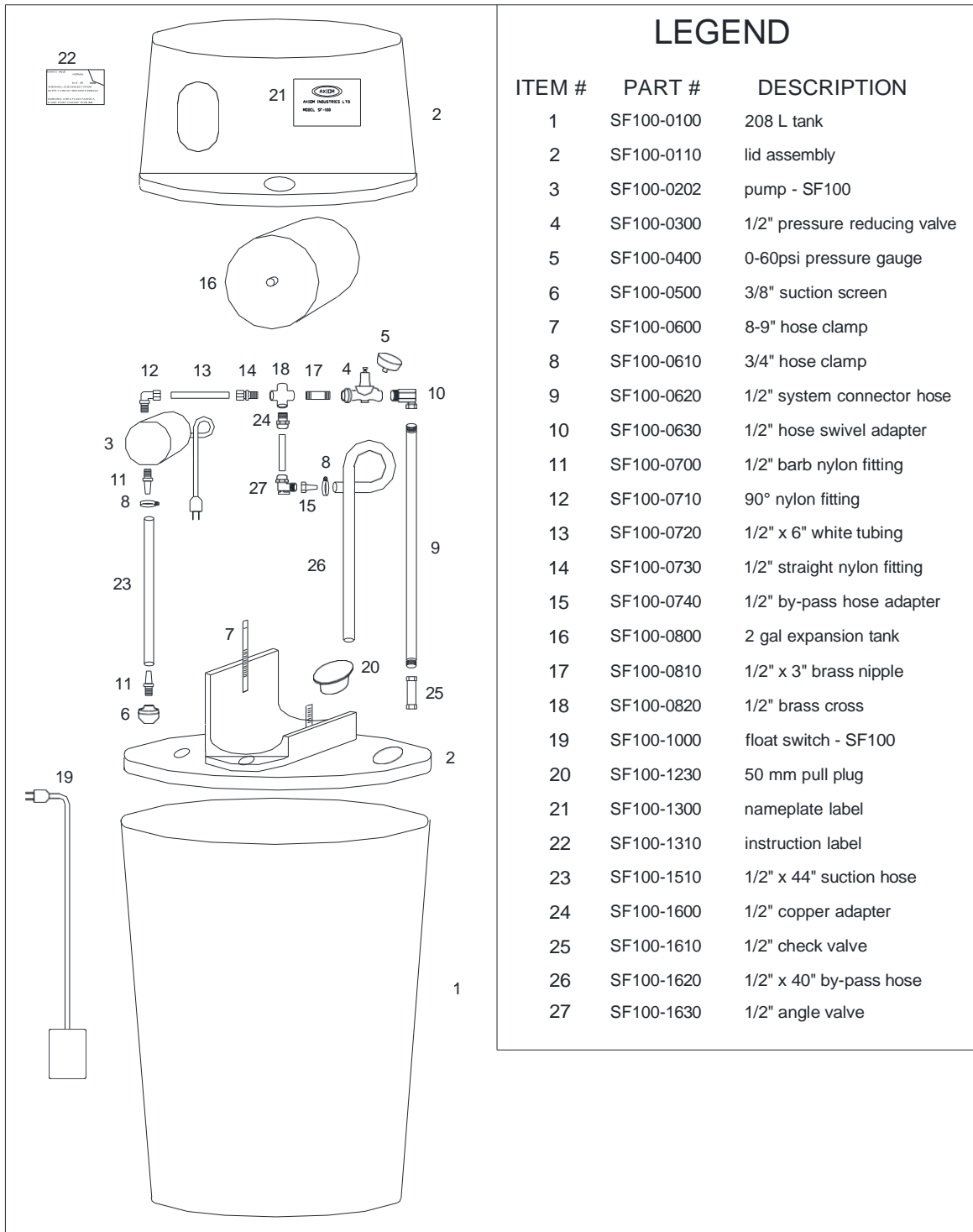

## LEGEND

| ITEM # | PART #     | DESCRIPTION                  |
|--------|------------|------------------------------|
| 1      | SF100-0100 | 208 L tank                   |
| 2      | SF100-0110 | lid assembly                 |
| 3      | SF100-0202 | pump - SF100                 |
| 4      | SF100-0300 | 1/2" pressure reducing valve |
| 5      | SF100-0400 | 0-60psi pressure gauge       |
| 6      | SF100-0500 | 3/8" suction screen          |
| 7      | SF100-0600 | 8-9" hose clamp              |
| 8      | SF100-0610 | 3/4" hose clamp              |
| 9      | SF100-0620 | 1/2" system connector hose   |
| 10     | SF100-0630 | 1/2" hose swivel adapter     |
| 11     | SF100-0700 | 1/2" barb nylon fitting      |
| 12     | SF100-0710 | 90° nylon fitting            |
| 13     | SF100-0720 | 1/2" x 6" white tubing       |
| 14     | SF100-0730 | 1/2" straight nylon fitting  |
| 15     | SF100-0740 | 1/2" by-pass hose adapter    |
| 16     | SF100-0800 | 2 gal expansion tank         |
| 17     | SF100-0810 | 1/2" x 3" brass nipple       |
| 18     | SF100-0820 | 1/2" brass cross             |
| 19     | SF100-1000 | float switch - SF100         |
| 20     | SF100-1230 | 50 mm pull plug              |
| 21     | SF100-1300 | nameplate label              |
| 22     | SF100-1310 | instruction label            |
| 23     | SF100-1510 | 1/2" x 44" suction hose      |
| 24     | SF100-1600 | 1/2" copper adapter          |
| 25     | SF100-1610 | 1/2" check valve             |
| 26     | SF100-1620 | 1/2" x 40" by-pass hose      |
| 27     | SF100-1630 | 1/2" angle valve             |

|                |            |                 |          |                  |  |
|----------------|------------|-----------------|----------|------------------|--|
| PROJECT        |            | SF100 (EXPLODE) |          | AXIOM INDUSTRIES |  |
| CUSTOMER       |            |                 |          |                  |  |
| DRWG. NO.      | EQUIP. NO. | JOB NO.         | DATE     |                  |  |
| TLL-SF100-0212 | PARTS LIST |                 | JAN 2014 |                  |  |





# INDUSTRIES LIMITED

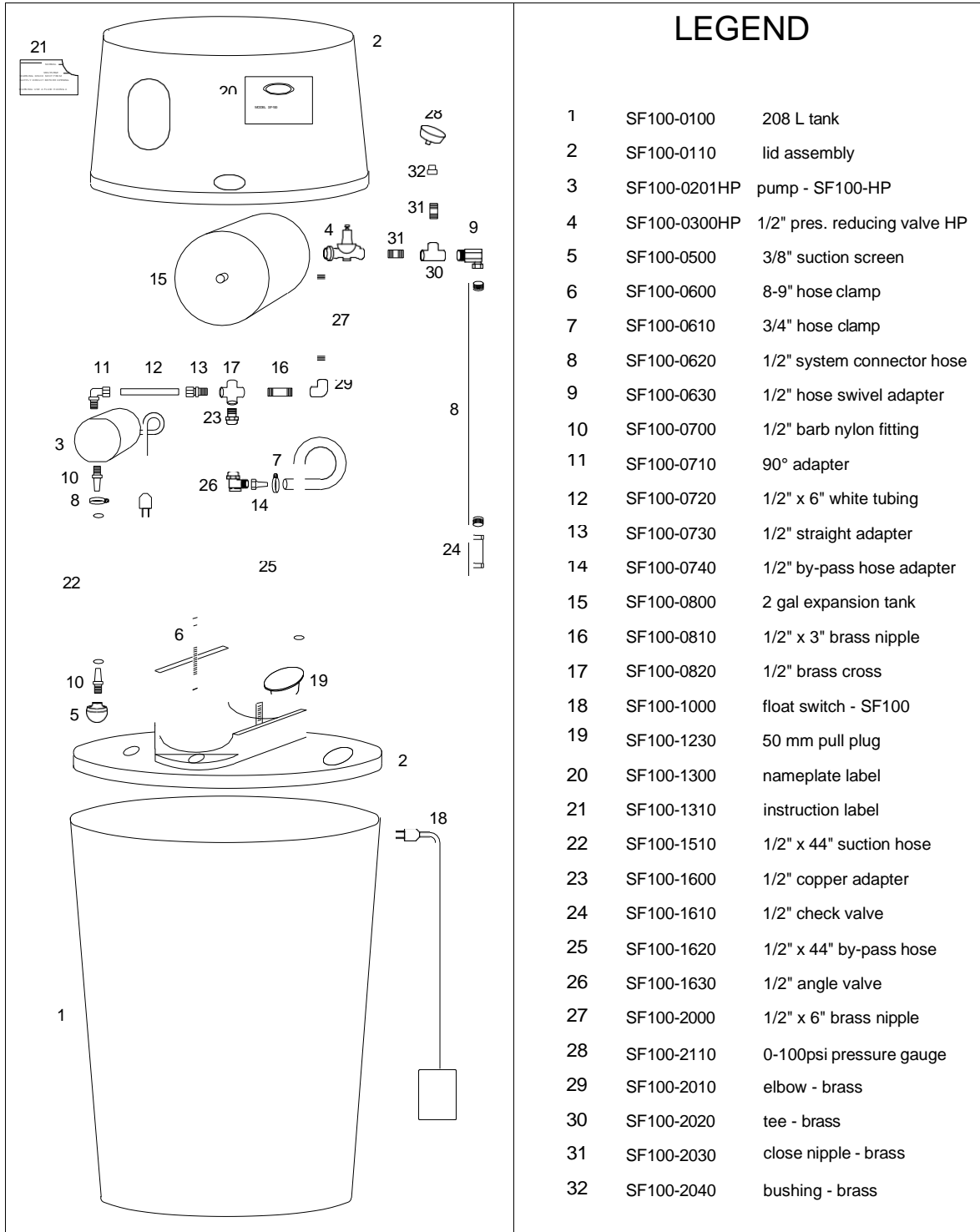

## LEGEND

|    |              |                              |
|----|--------------|------------------------------|
| 1  | SF100-0100   | 208 L tank                   |
| 2  | SF100-0110   | lid assembly                 |
| 3  | SF100-0201HP | pump - SF100-HP              |
| 4  | SF100-0300HP | 1/2" pres. reducing valve HP |
| 5  | SF100-0500   | 3/8" suction screen          |
| 6  | SF100-0600   | 8-9" hose clamp              |
| 7  | SF100-0610   | 3/4" hose clamp              |
| 8  | SF100-0620   | 1/2" system connector hose   |
| 9  | SF100-0630   | 1/2" hose swivel adapter     |
| 10 | SF100-0700   | 1/2" barb nylon fitting      |
| 11 | SF100-0710   | 90° adapter                  |
| 12 | SF100-0720   | 1/2" x 6" white tubing       |
| 13 | SF100-0730   | 1/2" straight adapter        |
| 14 | SF100-0740   | 1/2" by-pass hose adapter    |
| 15 | SF100-0800   | 2 gal expansion tank         |
| 16 | SF100-0810   | 1/2" x 3" brass nipple       |
| 17 | SF100-0820   | 1/2" brass cross             |
| 18 | SF100-1000   | float switch - SF100         |
| 19 | SF100-1230   | 50 mm pull plug              |
| 20 | SF100-1300   | nameplate label              |
| 21 | SF100-1310   | instruction label            |
| 22 | SF100-1510   | 1/2" x 44" suction hose      |
| 23 | SF100-1600   | 1/2" copper adapter          |
| 24 | SF100-1610   | 1/2" check valve             |
| 25 | SF100-1620   | 1/2" x 44" by-pass hose      |
| 26 | SF100-1630   | 1/2" angle valve             |
| 27 | SF100-2000   | 1/2" x 6" brass nipple       |
| 28 | SF100-2110   | 0-100psi pressure gauge      |
| 29 | SF100-2010   | elbow - brass                |
| 30 | SF100-2020   | tee - brass                  |
| 31 | SF100-2030   | close nipple - brass         |
| 32 | SF100-2040   | bushing - brass              |

|           |            |                    |              |                  |  |
|-----------|------------|--------------------|--------------|------------------|--|
| PROJECT   |            | SF100-HP (EXPLODE) |              | AXIOM INDUSTRIES |  |
| DRWG. NO. | EQUIP. NO. | JOB NO.            | DATE         |                  |  |
|           | PARTS LIST |                    | 20 JUNE 2013 |                  |  |



**SF100 Installation Instructions for the RIA10-1-SAA Control Panel**

1. Mount the RIA10-1-SAA control panel on a wall next to the SF100 Glycol Feed System.
2. Cut the plug-in end of the tank float cord
3. Push the float cable through strain relief fitting in control panel and connect float wires to terminals 1 and 2 on terminal strip. Connect ground wire to ground connection. Tighten strain relief nut to secure cable into panel.
4. Connect DCS wiring to remote alarm dry contacts as requested to provide alarm signal.
5. To disable the audible alarm, remove the jumper on the control board.
6. Plug pump cord into RIA10-1-SAA panel.

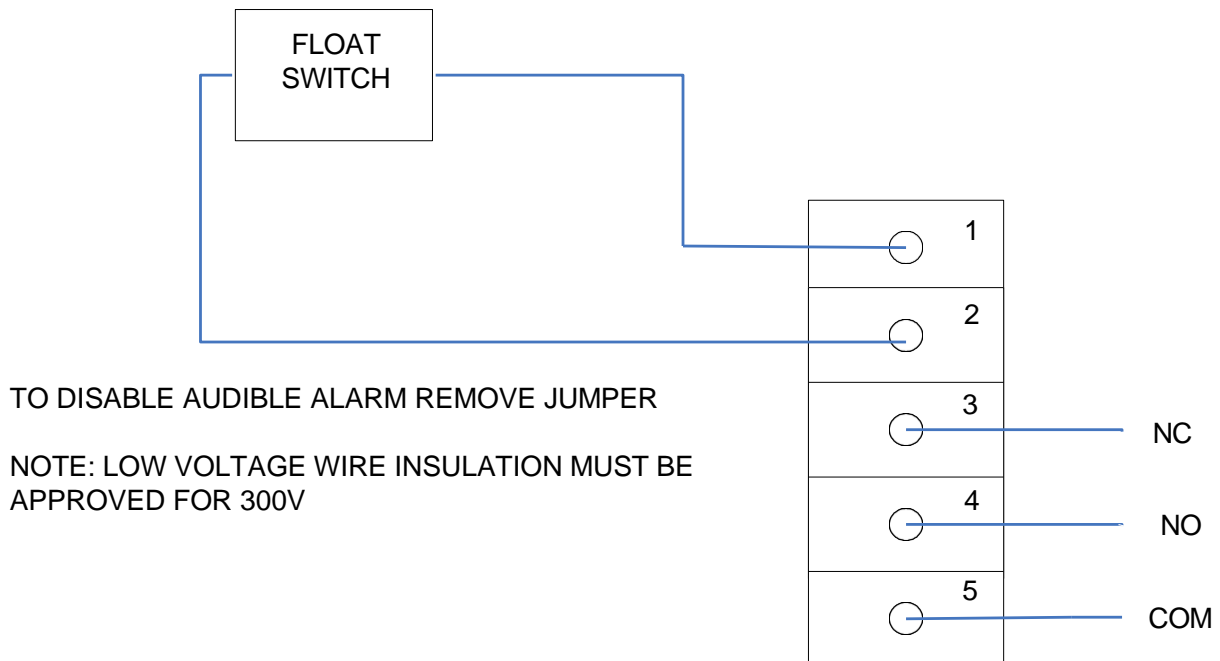

## SF100 trouble shooting chart

### Symptom

### Possible Cause

### Resolution

#### **Pump will not start**

|   |   |
|---|---|
| Fluid level in tank is low                      | Add correct fluid. Check for cause of system fluid loss                           |
| Thermal fuse tripped                            | Allow pump sufficient time to cool down. Pumps are designed for intermittent duty |
| Power unplugged or loose electrical connections | Plug in power or correct faulty electrical connection                             |
| Pressure switch out of adjustment               | Adjust pressure switch according to the manufacturers recommendations             |
| Faulty pressure switch on pump                  | Obtain pump from reseller and replace   |
| Pump failure                                    | Obtain pump from reseller and replace   |

#### **Pump will not shut off**

|                                |                                       |
|--------------------------------|---------------------------------------|
| Air lock in pump               | Turn purge/mixing valve to prime pump |
| Leak in system or pump         | Inspect system and repair leak        |
| Faulty pressure switch on pump | Obtain pump from reseller and replace |

#### **Pump will not prime**

|  |  |
|--|--|
| Fluid level in tank is low                       | Add correct fluid. Check for cause of system fluid loss  |
| Strainer on inlet hose is blocked                | Clean strainer   |
| Product in tank is too thick or Congealed glycol | Clean strainer and check concentration of glycol mixture |
| Inlet tubing leak is drawing air                 | Replace tubing and repair leak                           |
| Inlet/Outlet tube severely restricted (Kinked)   | Replace tubing   |

#### **Noisy / Rough operation**

|  |   |
|--|---|
| Pump is overloaded and pump pressure switch not cutting out or cutting out at very high pressure | Obtain Replacement pump from reseller and install |
| Pump pressure switch cutting out at very high pressure   | Adjust pressure switch to lower pressure.         |
| Loose pump head or drive screws  | Tighten screws                                    |
| Feeder is plumbed with rigid pipe causing noise to transmit                                      | Plumb with PEX or plastic pipe                    |

#### **Feeder Leaking**

|                              |   |
|------------------------------|---|
| Loose fittings               | Tighten fittings                                  |
| Pump has punctured diaphragm | Obtain Replacement pump from reseller and install |

#### **System pressure low**

|   |   |
|---|---|
| Fluid level in tank is low                      | Add correct fluid. Check for cause of system fluid loss               |
| Breaker   | Flip breaker  |
| Pressure switch out of adjustment               | Adjust pressure switch according to the manufacturers recommendations |
| PRV adjusted to low pressure                    | Loosen jam nut and adjust hex screw clockwise to increase pressure    |
| PRV plugged                                     | Open bottom, remove screen if it is still there and clean thoroughly  |
| Faulty pressure switch                          | Obtain Replacement pump from reseller and install                     |
| Power unplugged or loose electrical connections | Plug in or correct faulty electrical connection                       |
| Pump failure                                    | Obtain pump from reseller and install                                 |

**System pressure to high**

|   |   |
|---|---|
| Pressure switch not adjusted to proper setpoint | Adjust pressure switch, refer to maintenance manual for instructions              |
| PRV adjusted to high pressure                   | Loosen jam nut and adjust hex screw counter clockwise to decrease system pressure |
| PRV fast fill valve open                        | Move fast fill lever to vertical position   |
| PRV plugged                                     | Open bottom, remove screen if it is still there and clean thoroughly              |

**Pump Cycles Continually**

|   |                                |
|---|--------------------------------|
| Air is being removed from system and pump is only making up fluid | No action required             |
| Leak in system  | Inspect system and repair leak |
| Bladder in expansion tank is broken                               | Replace expansion tank         |