



FH-10 SIDE STREAM FILTERPAK TECHNICAL INFORMATION

DIMENSIONS :

WEIGHT : 3.17 kg 7 lbs

PARTS :

SFP-10-5M : 5 micron cartridge replacement for 10" filter housing

SFP-10-10M : 10 micron cartridge replacement for 10" filter housing

SFP-10-25M : 25 micron cartridge replacement for 10" filter housing

SFP-10-0800 : EPDM O-Ring set

SFP-10-0900 : Opening tool for FH

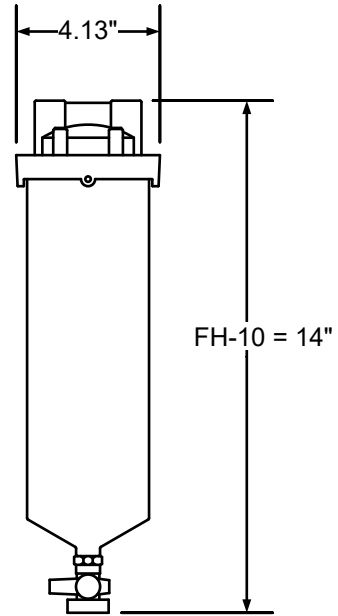

	Model	Size	Side Stream Flow Rate	Filter Size	Vessel Volume
<input type="checkbox"/>	FH-10	3/4"	1-10 gpm (0-38 lpm)	10" (254mm)DOE cotton wound	0.4 gal (1.5L)

SPECIFICATION :

Hydronic Filter Housing shall be AXIOM INDUSTRIES LTD. model FH-10. System shall include of 304SS filter housing with 304SS head, two EPDM O-rings, and brass drain valve with barb fitting and cap.

LIMITED WARRANTY :

The Axiom FH filter housing is warranted against defects in materials and workmanship for one year.

Project _____
 Consultant _____
 Unit Tag _____

Location _____
 Contractor _____
 Sales Agent _____