



## NC-2S Condensate Neutralizer Technical Information

**KIT CONTENTS:**



No.	Parts Description
A	Four NC Series O-Ring for Canister
B	Two NC Series Union
C	Two 3/4" NPT to 3/4" PVC socket weld
D	Two Base/Wall Mounting Clamps

**DIMENSIONS:**

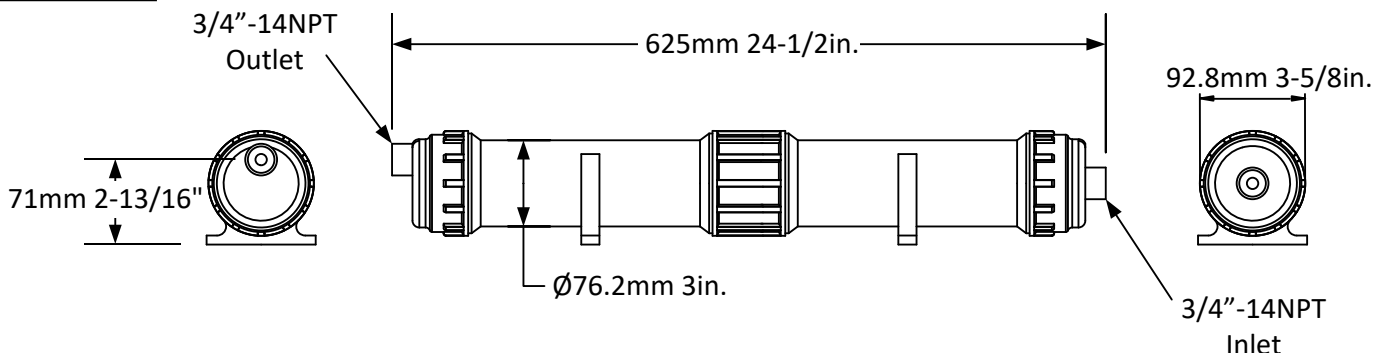

**WEIGHT:** 3.5 kg, 7.7 lbs. (dry weight with Media)

**SPECIFICATION:**

The condensate neutralization capsule shall be AXIOM INDUSTRIES LTD. model NC-2S. System shall include 2 litre (0.53 U.S. gallon) transparent capsule made from corrosion resistant materials with two 3" fill/access openings, 3" inlet and outlet screen, 3/4"-14NPT threaded inlet, 3/4"-14NPT threaded outlet, two 3/4" MNPT x 3/4" FNPT unions two 3/4" NPT to 3/4" PVC socket weld schedule 40 fittings, two base/wall mounting clamps.

**OPTIONAL ACCESSORIES:**

- 2 x NM-1** -- Replacement LipHter<sup>+</sup> neutralization media (NM-1 x 2 for exact Refill)
- NM-1BULK** -- Replacement LipHter<sup>+</sup> neutralization media (Up to 7 Refills)

**LIMITED WARRANTY:**

The "NC-2S" is warranted against defects in materials and workmanship for one year.



Project \_\_\_\_\_  
 Consultant \_\_\_\_\_  
 Unit Tag \_\_\_\_\_

Location \_\_\_\_\_  
 Contractor \_\_\_\_\_  
 Sales Agent \_\_\_\_\_