

Condensate Neutralizer

AXIOM

NT25-P18



- A Combination Neutralizer + Removal Pump
- A Maximum delivery head 6m (20ft)
- A Low profile design for appliances with near floor condensate drain
- A 18 litre (4.8 US gallon) tank with baffles designed to channel flow through LipHter media for complete neutralization
- A Comes with high level float for hook up to alarm system
- A NeutraPump prevents acidic condensate from corroding drains and sewer systems
- A Neutralized condensate is more environmentally friendly
- A All materials made from corrosion resistant material
- A Includes initial charge of Axiom's special LipHter neutralizing media

Featuring :

LipHter™

6,000,000 Btu/hr
(40 Gal/hr, 150 l/hr)

* Check with the appliance manufacturer for condensate flowrate or go to our website and use the sizing calculator. As a guideline 6,000,000 BTU/hr at 96% efficiency will produce approximately 40 Gal/hr (150 l/hr).

The NT25-P18 “NeutraPump” is ideal for installation that require both condensate removal and neutralization. The condensate produced by gas fired condensing appliances is acidic and has the potential to harm the environment and the sewer system.

✉ info@axiomind.com
☎ (877)651-1815
🌐 WWW.AXIOMIND.COM

NeutraPump™



NT25-P18 Condensate Neutralization Tank with Pump Technical Information

DIMENSIONS :

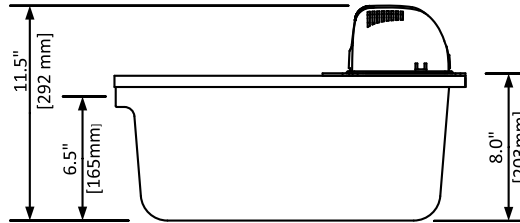
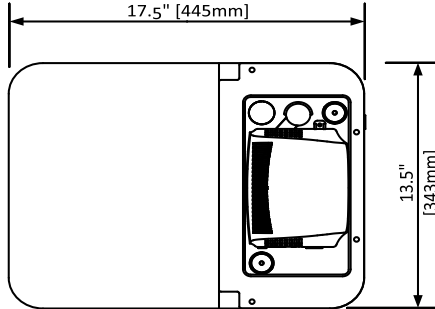

Pump is certified to
CAN/CSA STD
C22.2 no. 108

4007096
Pump Conforms to
ANSI/UL STD 778

WEIGHT :

23 kg, 51 lbs. (dry weight with Media)

PUMP ELECTRICAL :

Pump: 120VAC 60Hz, 87W, 0.89 Amps
High level safety switch rating: 125 or
250 VAC 6A, 125 V DC 0.4A, 250 V DC 0.3A

PUMP PERFORMANCE :

Submerged pump is self-priming
282 l/hr (74 gph) @ free flow
150 l/hr (40gph) @ 5.5 m (18ft)

NT25-P18 Pump Curve

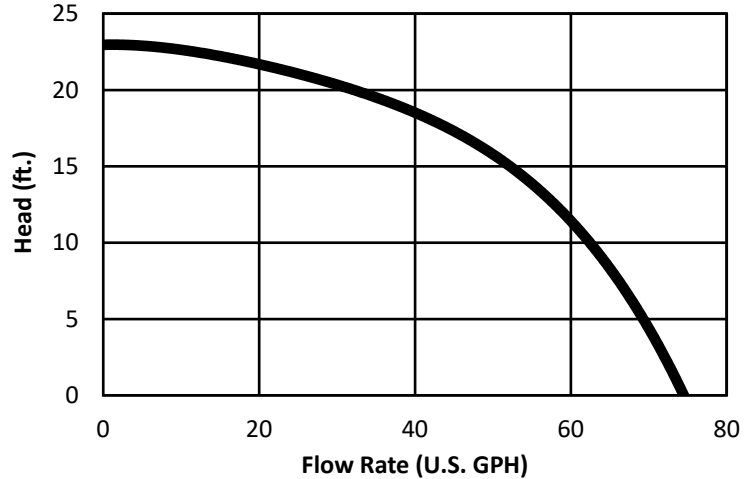

SPECIFICATION :

The condensate neutralization tank with pump shall be AXIOM INDUSTRIES LTD. Model NT25-P18. System shall include 18 liter (4.8 U.S. gallon) tank and lid made from polypropylene construction; S.S. mounting bracket and screws; pump with thermal cut-out and electrically certified to CAN/CSA std C22.2 no. 108-1 and conforms to ANSI/UL std 778; low level float switch; high level float switch with N.C. or N.O. contacts (factory set to N.C.) for remote alarm system; check valve; 20 ft of 3/8 vinyl tubing; 1" FNPT inlet; 1" FNPT x 1" MNPT PVC union; 6ft. long power cord. power supply 110/60/1 1.9A. comes with 18kg (40lbs) of Axiom's LipHter neutralization media.

OPTIONAL ACCESSORIES :

- NM-25** -- Replacement LipHter neutralization media (Exact Refill)
- RIA10-1-SAA** -- High level alarm panel provides audible and visual alarm for high level indication.

LIMITED WARRANTY :

The NT25-P18 is warranted against defects in materials and workmanship for one year.



Project _____
Consultant _____
Unit Tag _____

Location _____
Contractor _____
Sales Agent _____