

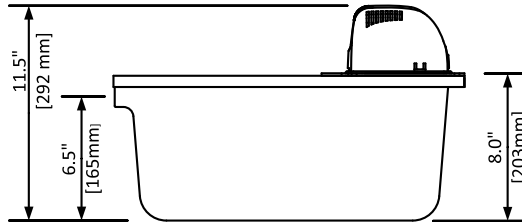

NT25-P18 Condensate Neutralization Tank with Pump Technical Information

DIMENSIONS :

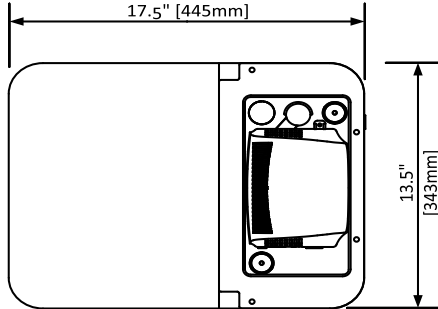

Pump is certified to
CAN/CSA STD
C22.2 no. 108

4007096
Pump Conforms to
ANSI/UL STD 778

WEIGHT :

23 kg, 51 lbs. (dry weight with Media)

PUMP ELECTRICAL :

Pump: 120VAC 60Hz, 87W, 0.89 Amps
High level safety switch rating: 125 or
250 VAC 6A, 125 V DC 0.4A, 250 V DC 0.3A

PUMP PERFORMANCE :

Submerged pump is self-priming
282 l/hr (74 gph) @ free flow
150 l/hr (40gph) @ 5.5 m (18ft)

NT25-P18 Pump Curve

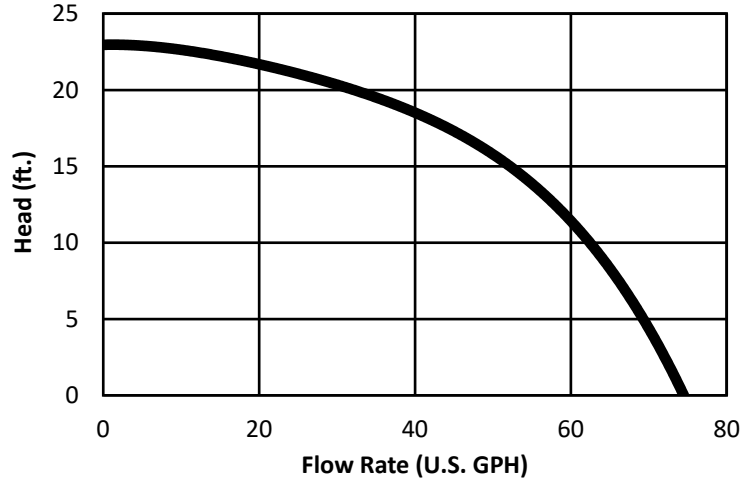

SPECIFICATION :

The condensate neutralization tank with pump shall be AXIOM INDUSTRIES LTD. Model NT25-P18. System shall include 18 liter (4.8 U.S. gallon) tank and lid made from polypropylene construction; S.S. mounting bracket and screws; pump with thermal cut-out and electrically certified to CAN/CSA std C22.2 no. 108-1 and conforms to ANSI/UL std 778; low level float switch; high level float switch with N.C. or N.O. contacts (factory set to N.C.) for remote alarm system; check valve; 20 ft of 3/8 vinyl tubing; 1" FNPT inlet; 1" FNPT x 1" MNPT PVC union; 6ft. long power cord. power supply 110/60/1 1.9A. comes with 18kg (40lbs) of Axiom's LipHter neutralization media.

OPTIONAL ACCESSORIES :

- NM-25** -- Replacement LipHter neutralization media (Exact Refill)
- RIA10-1-SAA** -- High level alarm panel provides audible and visual alarm for high level indication.

LIMITED WARRANTY :

The NT25-P18 is warranted against defects in materials and workmanship for one year.



Project _____
Consultant _____
Unit Tag _____

Location _____
Contractor _____
Sales Agent _____