

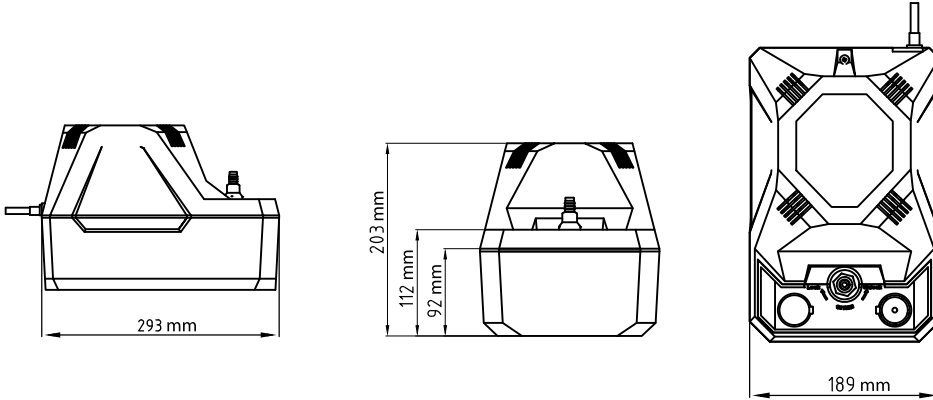

AP43-HTS Condensate Pump Technical Information

Dimensions :



Pump is certified to
CAN/CSA STD
C22.2 no. 108

4007096
Pump conforms to
ANSI/UL STD 778

Tank : 3.8 Litre

Weight : 3.13 kg, 6.90 lbs (empty)
6.6 kg, 14.6 lbs (full)

Electrical :

Pump: 120 VAC 60Hz, 226W, 1.91 Amps
High level safety switch rating : 125 or
250VAC 6A, 125V DC 0.4A, 250V DC 0.3A

Pump Performance :

Submerged pump is self-priming
282 L/hr (74 gph) @ free flow
123 L/hr (32 gph) @ 7 m (23ft)

AP43-HTS Pump Curve

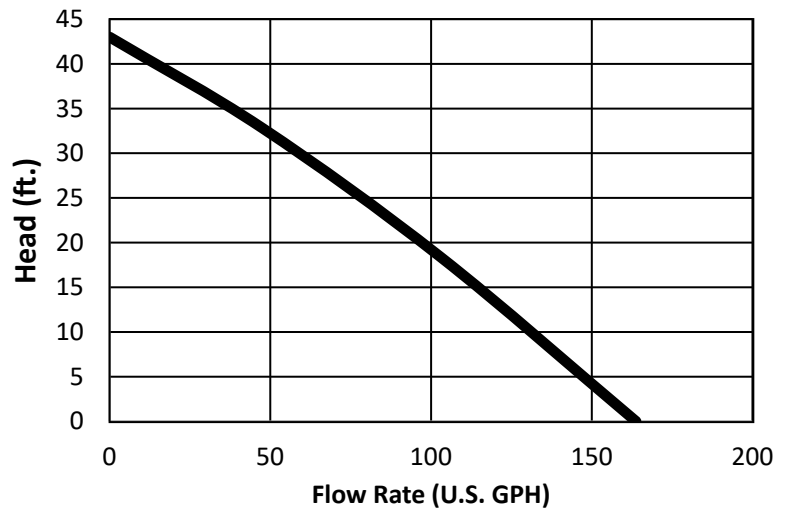

Specifications :

The condensate pump shall be AXIOM INDUSTRIES LTD. Model AP43-HTS. System shall include 3.5 litre (0.9 U.S. gallon) tank made and lid made from ABS, pump with thermal cut-out and electrically certified to CAN/CSA STD C22.2 no. 108 conforms to ANSI/UL STD 778; low level float switch; high level float switch with N.C. or N.O. contacts (factory set to N.C.) for remote alarm system; check valve; 6 ft. long power cord. Power supply 120/60/1.91A.

LIMITED WARRANTY

The “ **AP43-HTS** ” is warranted against defects in materials and workmanship for two years.

Project Details :

Project _____
Consultant _____
Unit Tag _____

Location _____
Contractor _____
Sales Agent _____